

Vanguard® FH 372s Installation Guide

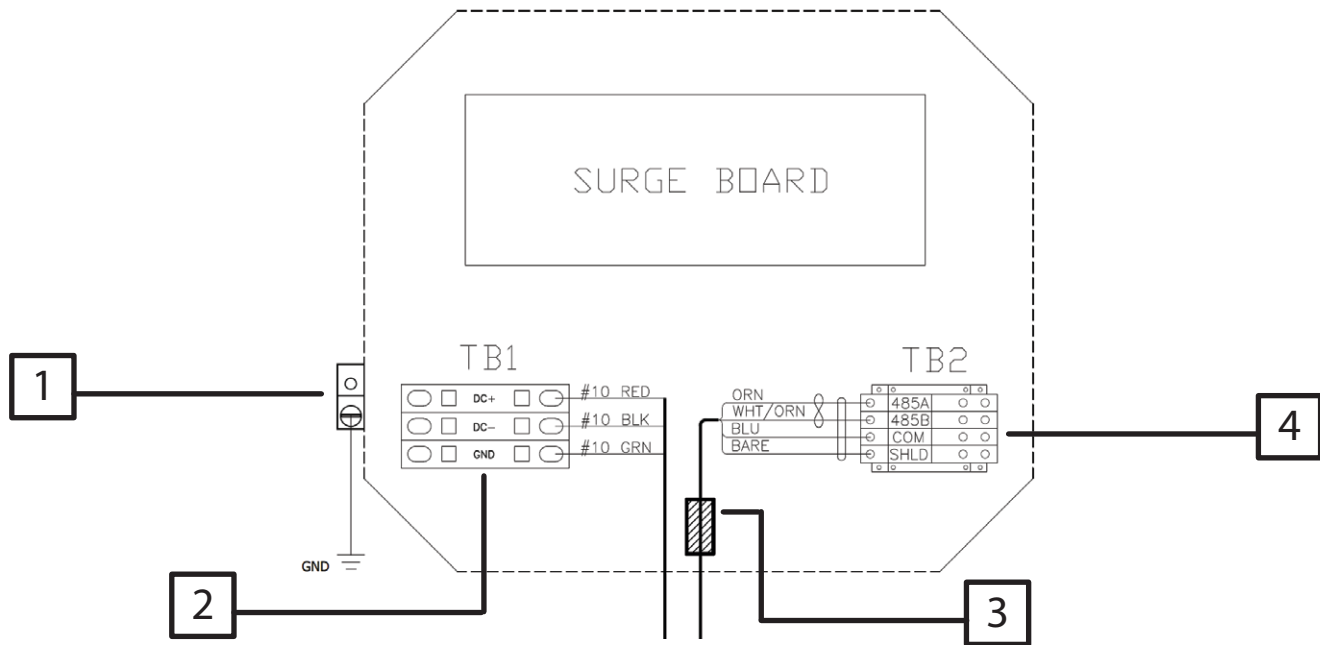

1 Grounding Connection

Connect a 2 AWG ground wire to the pre-installed lug on the FH 372s base. Route the other end of the wire to tower steel, buss bar or a customer preferred location.

Use an anticorrosive agent on both wire ends and avoid creating sharp bends when routing the ground wire.



2 Input Power Cable Terminal Block - TB1

Connect the supplied DC power cable to TB1 as shown below. This supplies ~58VDC from the connected power converter (PC 372) to operate the LED flashhead.

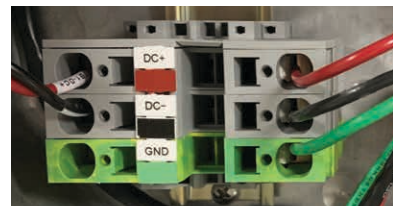

3 Ferrite Core Installation

One 280 Ohm hinged ferrite will be included for each LED flashhead.

Install the provided ferrite core on the RS-485 communication cable as close to the entry port as possible. The ferrite core will help stabilize communications in rugged installation conditions.

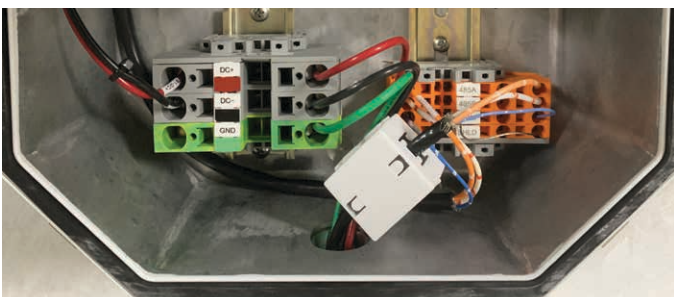

4 Communication Cable terminal Block - TB2

The supplied RS-485 communication cable contains three individual conductors and one shield wire. This cable provides the FH 372s a 2-way communication path with the ground level controller (FTC 270).

Wire Color (RS-485)	TB Position
Orange	485A
White/Orange	485B
Blue	COM
Bare	SHLD

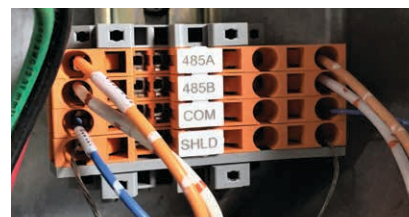

FH 372s Installation Steps

The information listed below outlines the basic steps for the LED flashhead (FH 372s) installation. More detail can be found in the drawing package provided for this site and the users manual P# F7912700. It assumes that a Flash Technology provided conduit and installation kit was used during initial installation.

1. Secure the four feet of the flashhead to the mounting surface. Use the provided hardware (P# F5991740).
2. Open the FH by releasing the two outer latches.
3. Install the provided flexible conduit and fittings to the threaded opening in the flashhead base.
4. Feed the flashhead power and RS-485 communication wires through the conduit. Remove ~4 inches of the outer jacket and foil for the RS-485 communication cable without damaging the individual conductor insulation. Remove ~1/2 inches of the insulation from each of the individual conductors.

5. Using a small flat-blade screwdriver, create an opening in each terminal position and securley seat each wire. Details shown below.

Wire Color (Power/DC Voltage)	TB Position
Red	DC+
Black	DC-
Green	GND

Wire Color (RS-485 Communication)	TB Position
Orange	485A
White/Orange	485B
Blue	COM
Bare	SHLD

6. Install the ferrite core on the RS-485 communication cable as close to the entry port as possible.

7. Ensure the "RS-485 ADDRESS SELECT" is in the correct position. Located on the circuit board in the upper portion of the FH 372s

Use the table to the right to ensure the right position is selected.



Rotary Dial Position	AOL Beacon Address
1	1
2	2
3	3
4	4
5	5
6	6
0, 7-9	Do not use

NOTE:

If there is only one FH 372s, then its position would be (1). A second FH 372s would be set to (2). Continue this numbering scheme for additional units.

8. Ensure the termination jumper, located directly above the RS-485 ADDRESS SELECT, is closed (black sleeve covering both pins).
If more than one FH 372s is present onsite, ensure the termination jumper is closed on the last FH 372s in the RS-485 communication link.

9. Connect a 2 AWG ground wire to the external ground lug of the flashhead base and appropriately route to the grounding location.

10. Close the FH by securing the two outer latches.



Call 1-800-821-5825 if additional TECHNICAL or INSTALLATION assistance is needed
(Monday - Friday, 7a.m - 7p.m CST).